



## PRODUCT CATALOGUE

### FORMWORK SYSTEM

**Rapid Scaffolding(Engineering)Co.,Ltd.**

Add:No.107 West Xigang Road, Xishan District,  
Wuxi City, Jiangsu Province, China

Tel: +86 510 83796833 Fax: +86 510 83795588

E-mail: [sales@rapid-scaffold.com](mailto:sales@rapid-scaffold.com)

[www.rapid-scaffold.com/en](http://www.rapid-scaffold.com/en)

**RAPID SCAFFOLDING(ENGINEERING)CO.,LTD.**



Our company has great location about 100km away from Shanghai Port, in which just 30 minutes away from Shanghai by train and one hour by car. Workshop area covers about 30,000m<sup>2</sup>, and warehouse about 10,000m<sup>2</sup>.

Rapid Scaffolding takes pride in having a team of highly experienced and suitably qualified engineering and technical experts. According to different requests from our clients, we can provide a whole range of scaffolding and formwork designing. We provide one-stop service for any project. We have a highly experienced production team, which maintains top level of every stage of the production progress. Each team of workers is led by a supervisor who monitors daily works. Automated welding and robot welding systems are widely used. We develop new steel plank forming machine, which increases plank production capacity, about 1,000pcs per day. With experienced workers, advanced machines and good management, our capacity is about 25,000tons per year.

We have a complete quality control system, which guarantees the high quality of our products and assure all process is due to schedule. Rapid Scaffolding (Engineering) Co., Ltd. has obtained ISO9001 Accreditation, CE, ISO14001, OHSAS18001. All our scaffolding systems are tested to confirm to ANSIA10.8, AS/NZS1576.3, Japan standard JIS.

## Rapid Scaffolding(Engineering)Co.,Ltd.

Rapid Scaffolding (Engineering)Co.Ltd. is a leading company in scaffolding industry in China. Since its establishment in 2003, RS has grown to take on new challenges and its continued success comes from valuing its clients and employees and a commitment to service, performance and quality. We are not only the expert in designing and manufacturing all kinds of steel scaffoldings and formwork system, but also we devote to being an expert in developing aluminum scaffoldings. our main products include Ringlock (Allround). Cup-lock, Kwikstage, Haky, Frames, Props, etc.



# Formwork System

## Timber-Beam Formwork

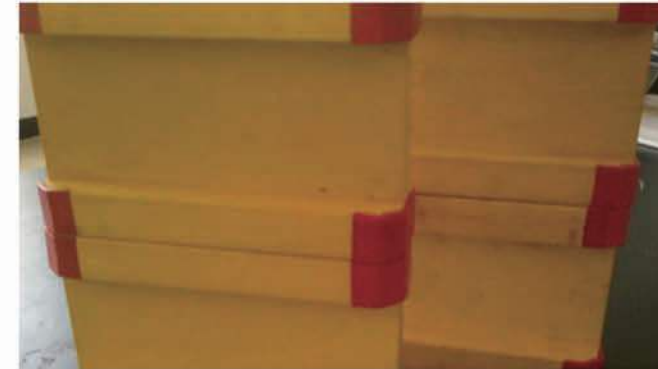

### 01 Timber Beam H20—cost-effective formwork girder

Wings :Spruce Wood(from Finland)  
Web: Cottonwood Plywood  
Glue: HENKEL Glue

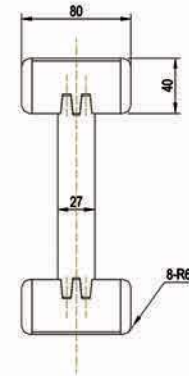
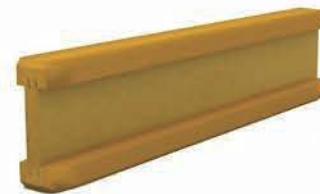

### Capacity

Standardized production lines.  
Supply capability: 3000m/day  
Lmax=6600mm.

### Characteristics

Finger jointing of the flange and web, the strength of timber beam is highly improved.  
Max. shearing force failure load:40KN  
Well treated to prevent from water penetration or erosion, so the service life maximally extended.  
Robust caps at the end of the girders protect against damages.

### 02 Plywood—make perfect concrete surface

WISA-Form Birch is a coated special plywood using in the formwork systems where high requirements are set on the concrete surface and the times of reuses.  
WISA-Form Birch.

Specification: T=18mm& T=21mm  
In standard thickness,  
Moisture content  $10 \pm 2\%$

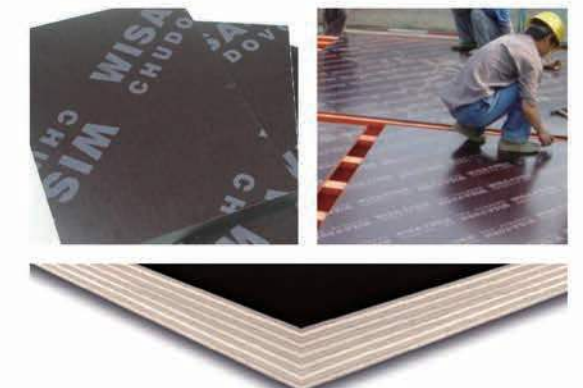

# Formwork System

## 03 Formwork

With timber beam & WISA plywood, the formwork is low weight but high load capacity, it is widely used in construction.



## Characteristics

Component with high standardization. Assembling in site, flexible application. Light weight, easy transportation and storage.



## Flat Formwork

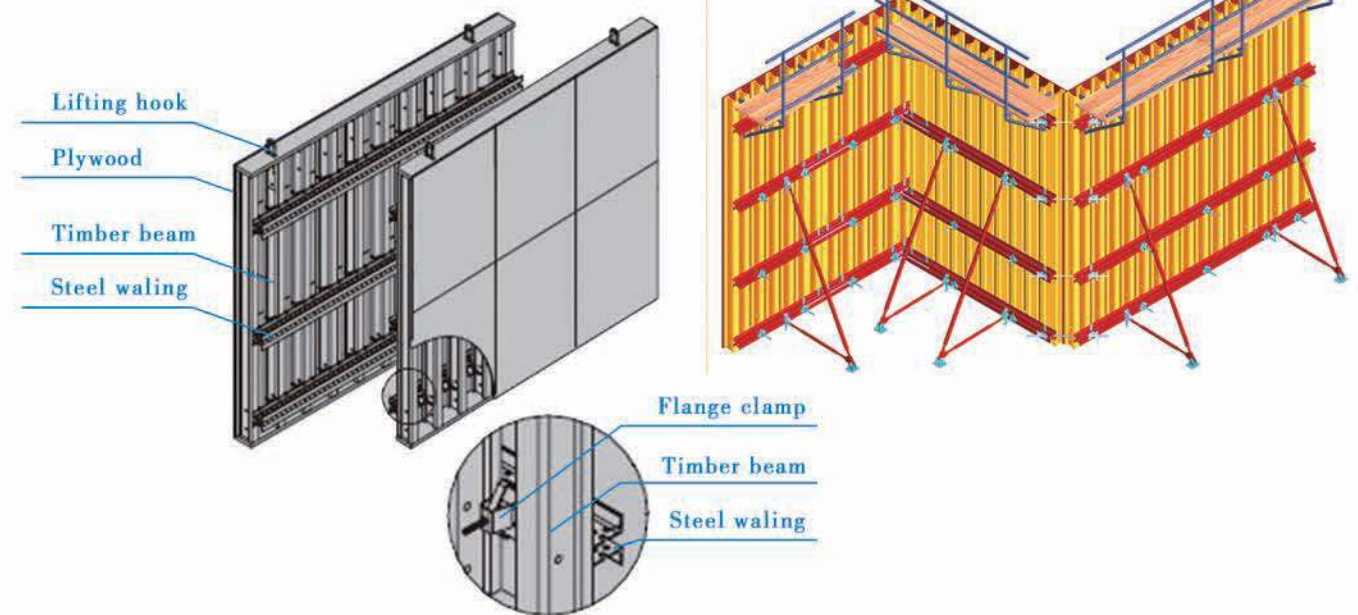











## Formwork System









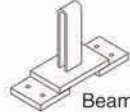
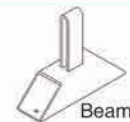

# Formwork System

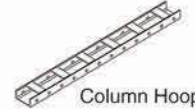
## 04 Accessories



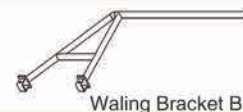





Name & Sketch	Weight	Tech. parameter	Remarks
 Flange Clamp	0.74kg 0.88kg 0.90kg	[10~[12 [14 [16	For connecting timber beam to steel waling
 Lifting Hook	4.65kg	H20	For lifting the formwork
 Stacking Plate	4.84kg	H20	For connecting the beams
 Timber Beam Bracket A	13.58kg		Install on the beam
 Formwork Element Connector	7.38kg 8.50kg 7.30kg 13.52kg	[10 [12 [12 L=820mm [14	For connecting waling length as required
 Shaft Waling Squaring Connector	8.44kg 10.64kg 16.08kg	[10 [12 [14	For connecting waling length as required
 Adjustable Shaft Waling Squaring Connector	9.16kg 9.48kg 12.82kg	[10 [12 [14	For connecting waling length as required
 Water Stop Connector	0.62kg 0.80kg	D15 D20	For wall-through tie-rod
 Tie-Yoke	2.30kg 2.20kg	[12 ~ [16 [10	For connecting upright formwork
 Beam Clamp A	1.44kg	[10	For connecting element connector

## 04 Accessories





Name & Sketch	Weight	Tech. parameter	Remarks
 Beam Clamp B	1.47kg	[12	For connecting element connector
 Beam Clamp C	1.09kg	[14 ~ [16	For connecting element connector
 Wedge	0.59kg		For connecting steel waling and element connector
 Gib Head Bolt	0.18kg 0.31kg	L=145mm L=253mm	For connecting wood batten and steel waling
 Column Hoop	12.01kg 21.76kg 16.28kg	[10 L=1200mm [12 L=1600mm [12 L=1200mm	[10 For the cube with the cross section less than 80x80cm; [12 For the cube with the section less than 120x120cm
 PVC Pipe Plug	0.008kg	Φ21.5 Φ27.5	
 PVC Joint	0.004kg	Φ26 Φ22 Φ31 Φ28	
 PVC Pipe Plug	0.004kg	Φ26	Other size can also be supplied as required
 Waling Bracket B	14.02kg		Install on the steel waling
 Wing Nut	0.35kg 0.62kg	D20 D15	For tie-rod D20, galvanized For tie-rod D15, galvanized

# Formwork System

## 04 Accessories

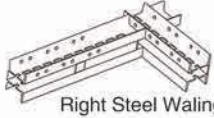
Name & Sketch	Weight	Tech. parameter	Remarks
 Hexagon Nut	0.18kg 0.56kg	D15 D20	For tie-rod D15, galvanized For tie-rod D20, galvanized
 Tri-Wings Nut	0.87kg 0.89kg	D15 D20	For tie-rod D15, galvanized For tie-rod D20, galvanized
 Flange Nut	0.63kg 0.65kg	D15 D20	For tie-rod D15, galvanized For tie-rod D20, galvanized
 Flange Nut	0.88kg 0.90kg	D15 D20	For tie-rod D15, galvanized For tie-rod D20, galvanized
 Super PlateNut	1.39kg	D15	For the situation that tie-rods and the panels are not vertical
 Two-Wings Nut	0.70kg	D15	For D15 tie-rod, galvanized
 Cast Washer Plate A	0.37kg 0.74kg 1.32kg	60X120mm 100x100mm 120x120mm	For tie-rod D15 For tie-rod D15 For tie-rod D20
 Punch Washer Plate	0.68kg	120x120mm	For tie-rod D20
 Steel Waling	10.85kg 17.44kg 14.47kg 34.88kg 28.94kg 66.54kg	[12 L=900mm [14 L=1200mm [12 L=1200mm [14 L=2400mm [12 L=2400mm [14 L=4800mm	

## 04 Accessories

产品&外观	重量	技术参数	备注
 Right Steel Waling	30.02kg	[12	
 Reversed Steel Waling	30.02kg	[12	
 Steel Waling		[14	
 Tie Rod	1.06kg 1.94kg	D20/L=300mm Max. load:270kN Allowable load:140kN D26.5/L=350mm Max. load:400kN Allowable load:200kN	Other length can be supplied as required the largest length is 12m galvanized as required
 Tie Rod	1.78kg 2.98kg 2.14kg 4.47kg 2.67kg 8.95kg 3.38kg 13.42kg 17.60kg	D15 L=1000mm D20 L=1000mm D15 L=1200mm D20 L=1500mm D15 L=1500mm D20 L=3000mm D15 L=1900mm D20 L=4500mm D20 L=5900mm	Other length can be supplied as required
		D20 Max. load:270kN Allowable load:140kN D15Max. load:160kN Allowable load: 85kN	

## Formwork System

### Adjustable Arced Formwork

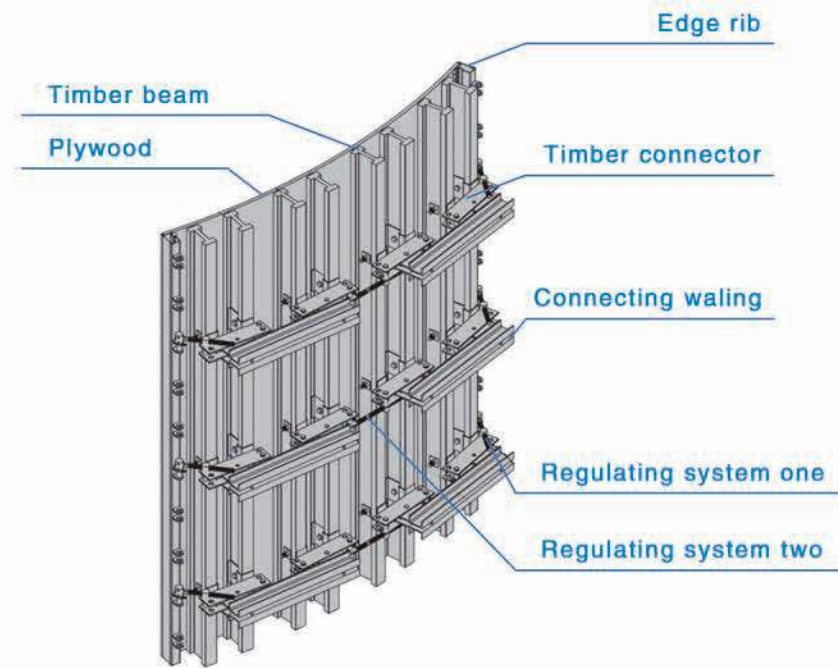

► For pouring arced wall or column with radius more than 1m.

#### ► Characteristics

Adjustable radius, flexible application.

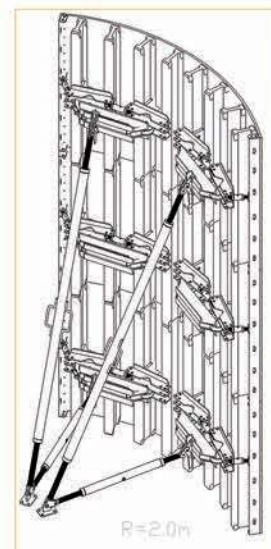
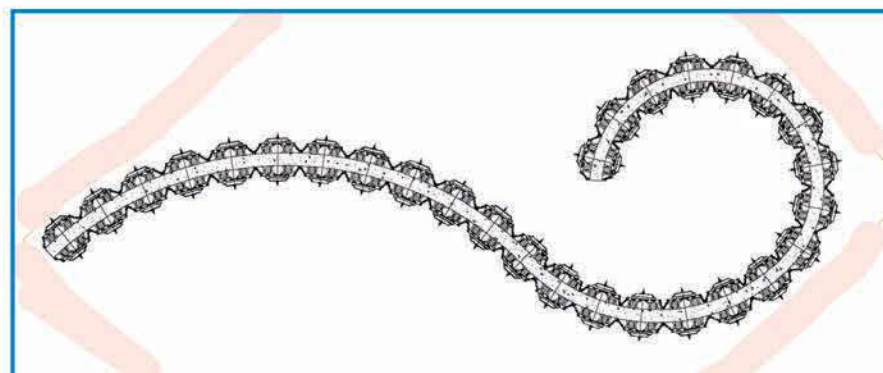



# Formwork System

## Table Formwork

- ▶ Table formwork is the most typical application for slab, with timber beam, the slab formwork is light weight, fast and economic in the construction.



### ▶ Table Formwork Sketch

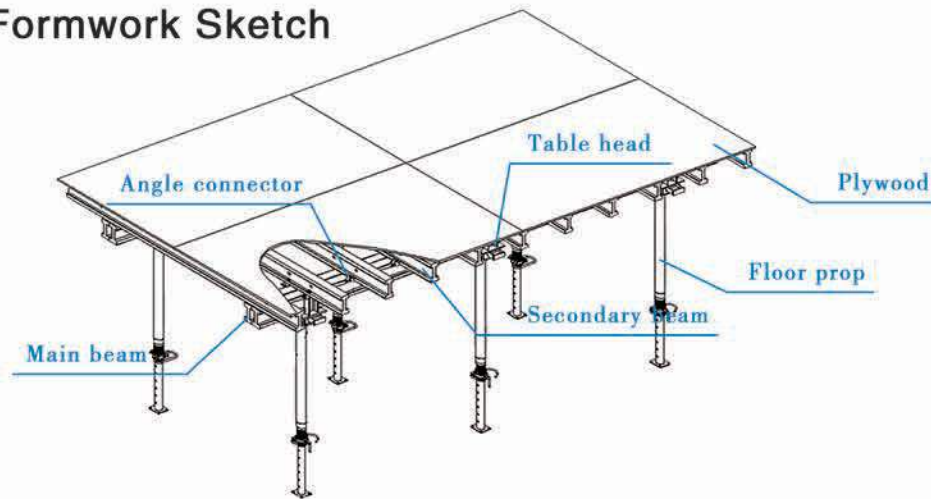

### ▶ Characteristics

Simple structure, easy assembly.

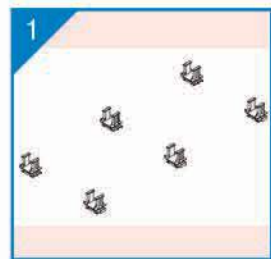

Arrange the table heads



Fix the main beams

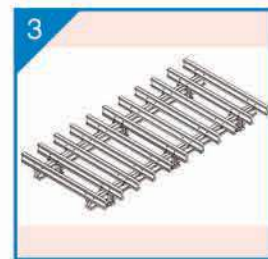

Fix the second beams

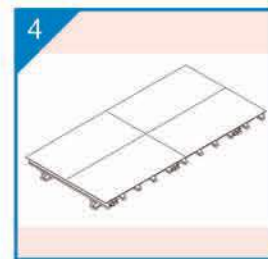

Fix the plywood



- ▶ Flexible structure, be adapted to different support system.

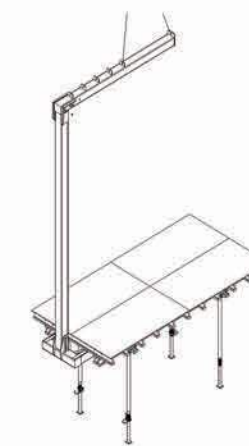
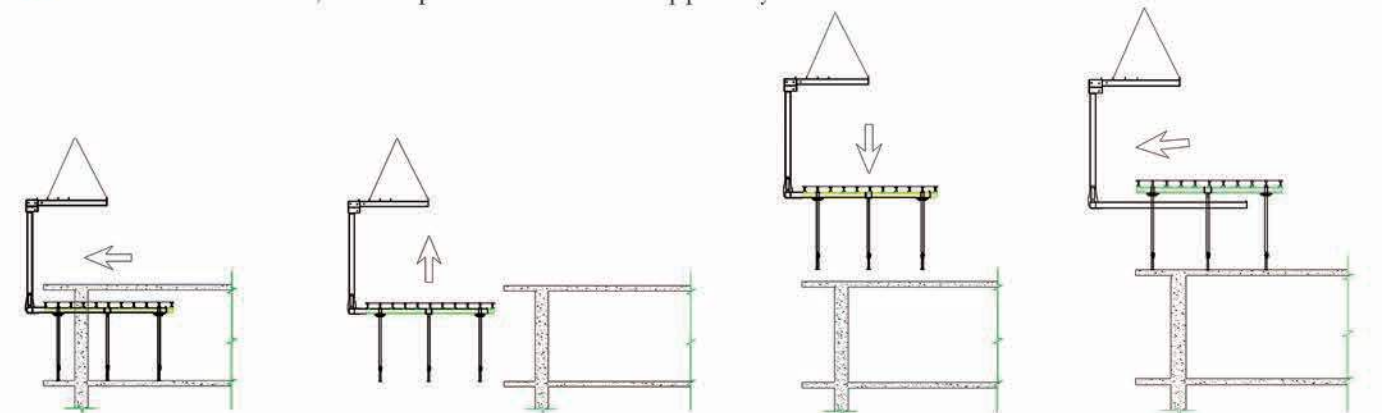

For Prop

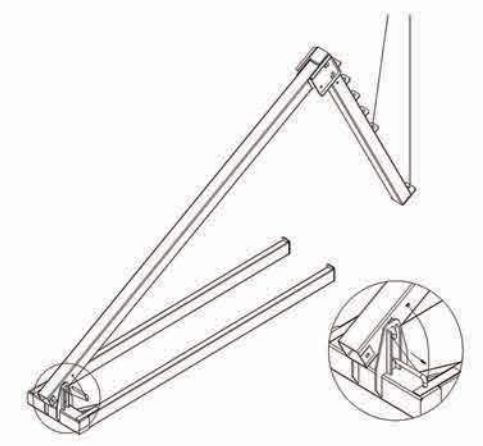

For Scaffolding

## Formwork System

- ▶ Trolley for moving the table formwork on floor. Flexible application with stand alone props. Safer condition with handrails.

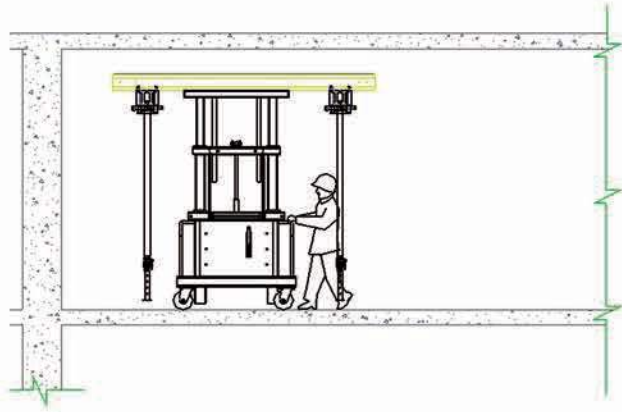





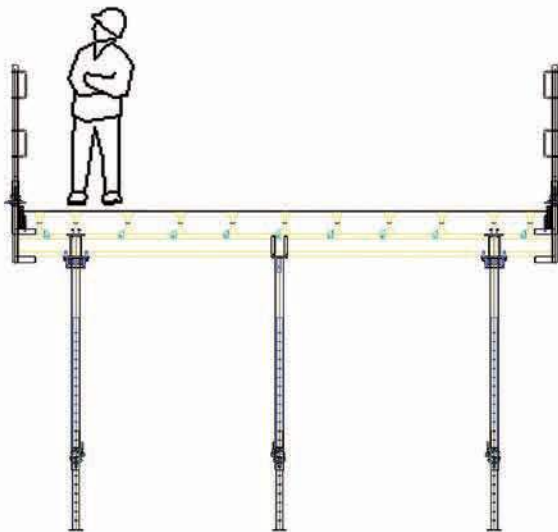
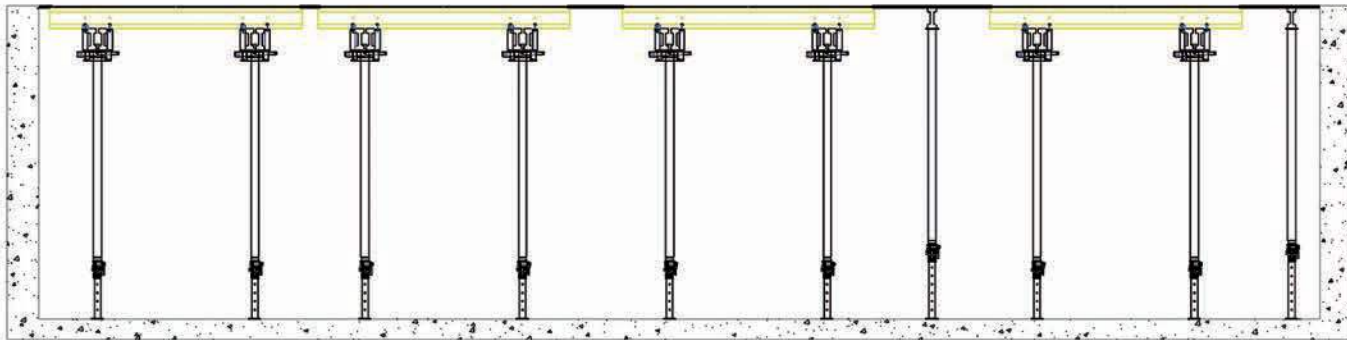

**Height**  
Standard device:  
Hmin=1750mm  
Hmax=3250mm  
Standard device  
with an attached frame:  
Hmin=2500mm  
Hmax=3900mm

**Bearing load**  
Standard device: 15~20KN  
Standard device  
with an attached frame: 11KN

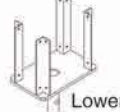

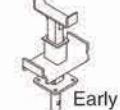
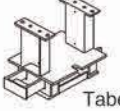
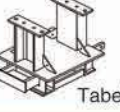

# Formwork System

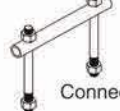
## Accessories

Name & Sketch	Weight	Tech. parameter	Remarks
 Lowering Head	3.45kg	L=328mm	For supporting timber beam
 U-Head	1.50kg	L=178mm	For supporting timber beam
 Straight Angle Jack	3.28kg 3.05kg	Φ61 L=160mm Φ50 L=160mm	For supporting timber beam
 Quick Striking Ring	2.28kg 2.09kg	Φ61 L=160mm Φ50 L=160mm	Used together with straight angle jack, for taking down beams quickly
 Early Stripping Head	7.49kg	L=460mm	For taking down beams quickly
 Tabel Head I	19.97kg		For double main beam
 Tabel Head II	16.73kg		For single main beam
 Angle Connector	0.09kg	2x67x90mm	For connect the beam
 Timber Beam Washer	0.01kg	2x31x25mm	For connecting second beam
 Connection Unit	1.13kg	M12	For connecting main beam

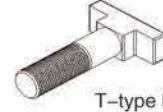
## Accessories

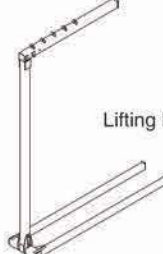
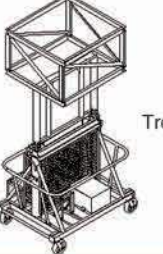
Name & Sketch	Weight	Tech. parameter	Remarks
 T-type Bolt	0.33kg	M20	For connecting main beam
 Handrail	14.53kg		For safe construction
 Lifting Fork	803.68kg		For lifting table formwork
 Trolley	707.04kg		For shifting table formwork

## Formwork System

### Steel-Frame Formwork SF-120



#### 02 Wall Formwork

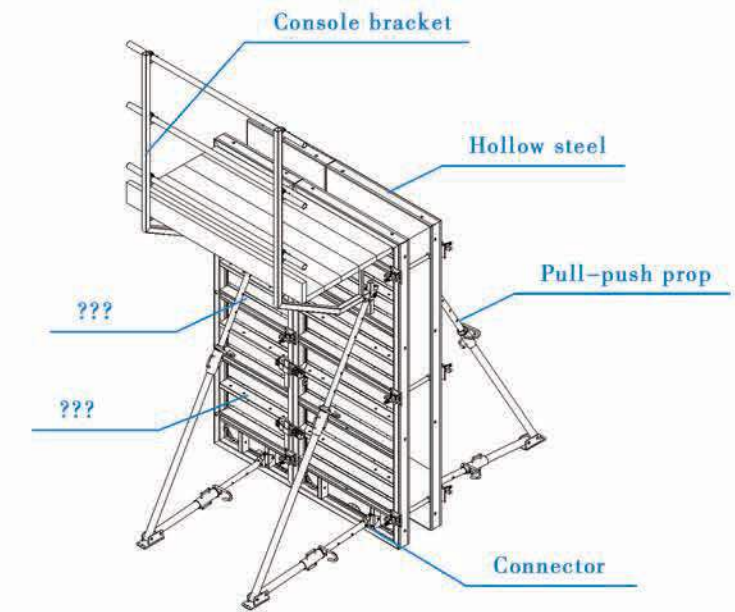

#### 01 Steel Frame

As the framework, it is adapted to the plywood with thickness of 18mm. High-precision production line guarantees the perfect products.



#### ► Characteristics

Special hollow steel frame covered with WISA-plywood, light weight but high strength. Its allowable pressure is 60kN/m<sup>2</sup> with the weight of 65kG/m<sup>2</sup>.

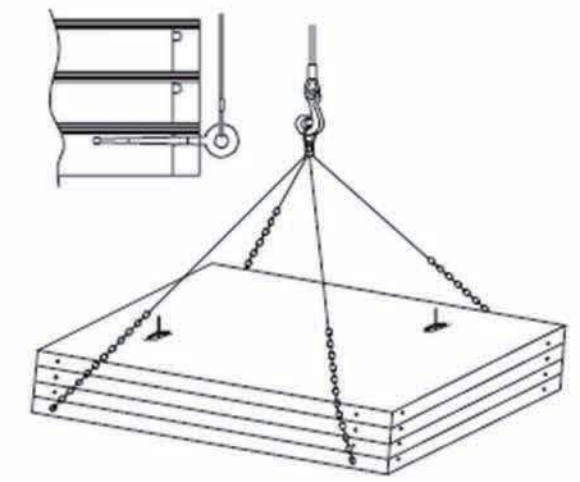
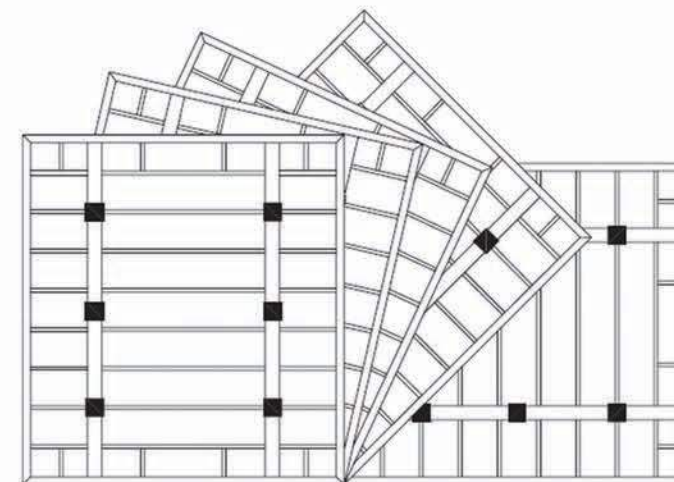

High standardized system

# Formwork System

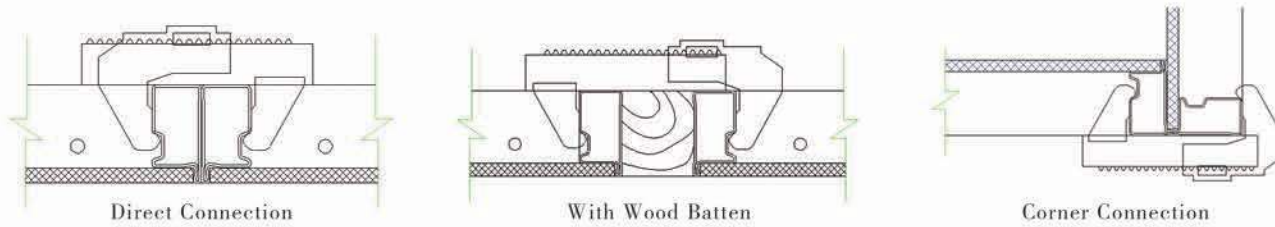
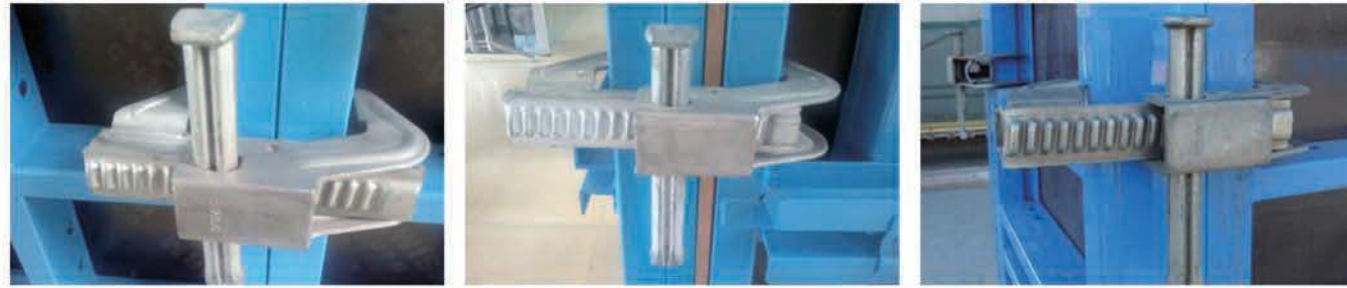

Easy connection with adjustable steel clamp

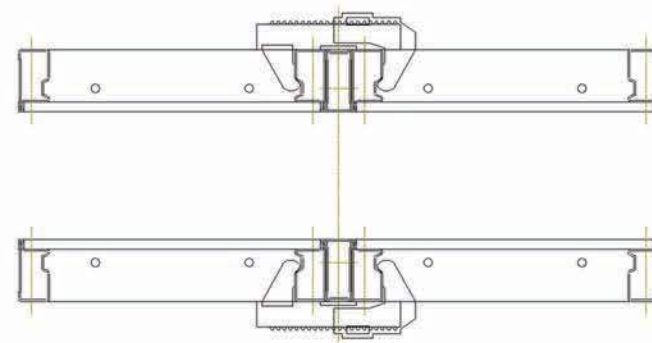

Convenient tie arrangement with the hole in frame

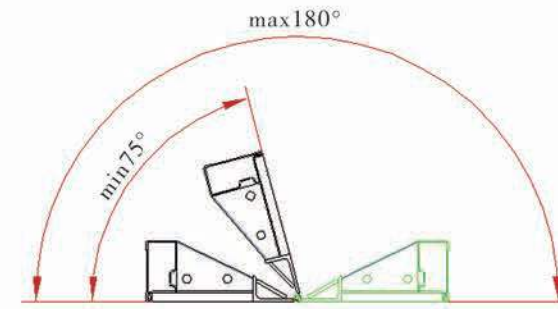
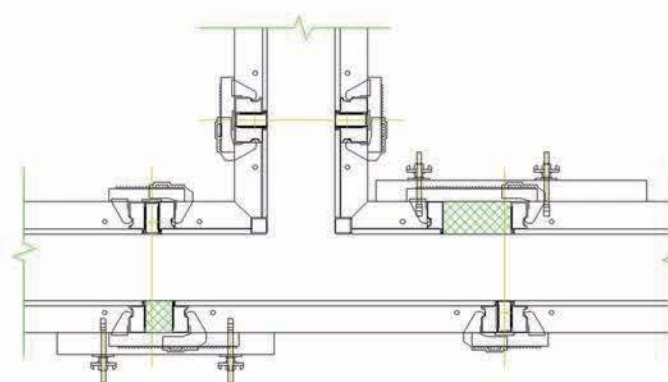
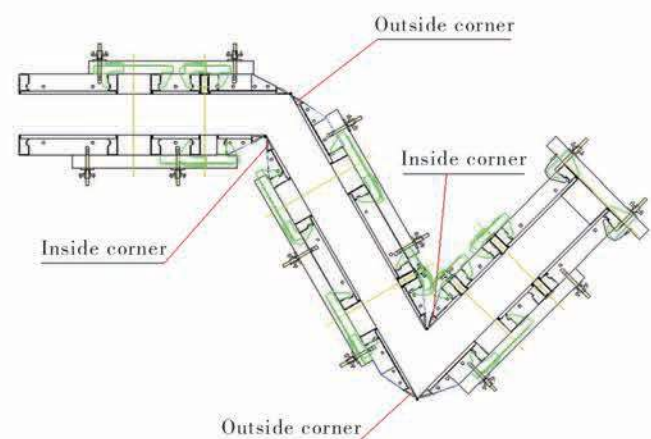

Articulated inside corner

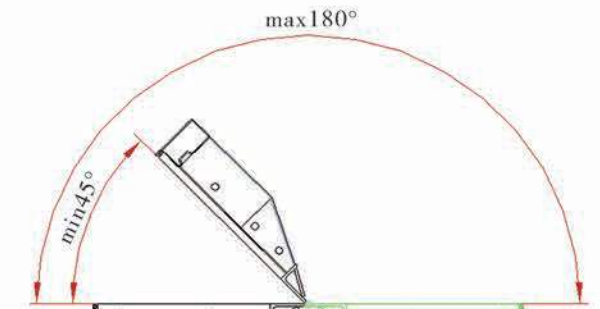

Articulated outside corner

Convenient and fast corner formwork

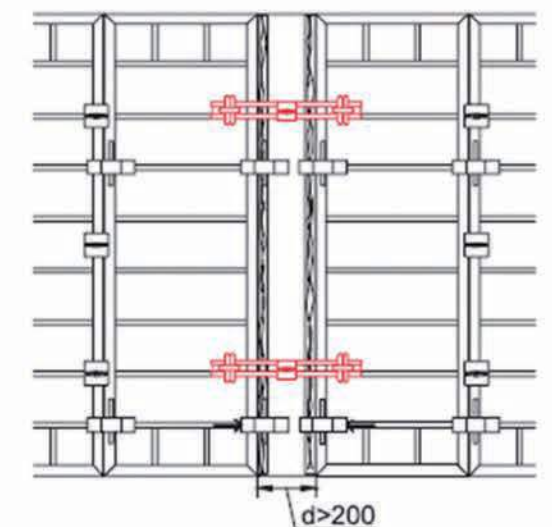
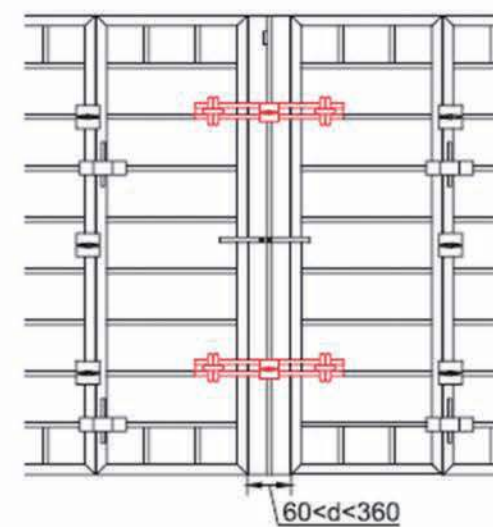
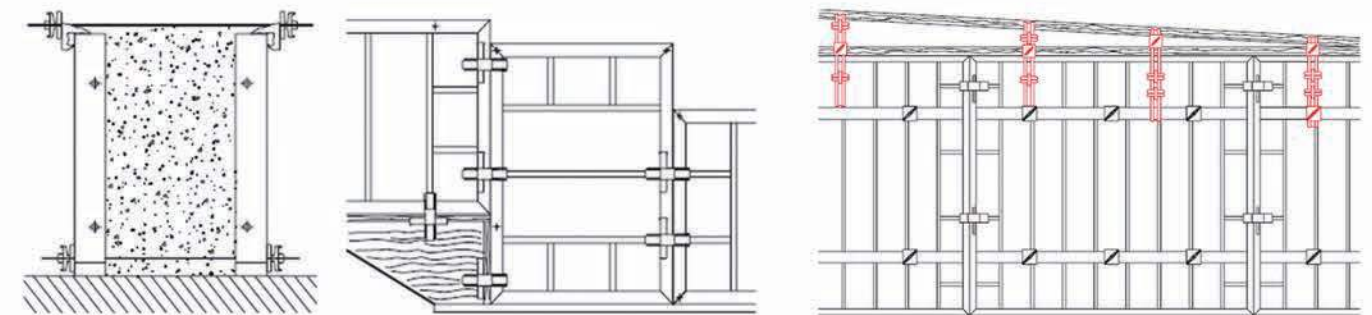

Flexible to assemble and application

# Formwork System 模板系统





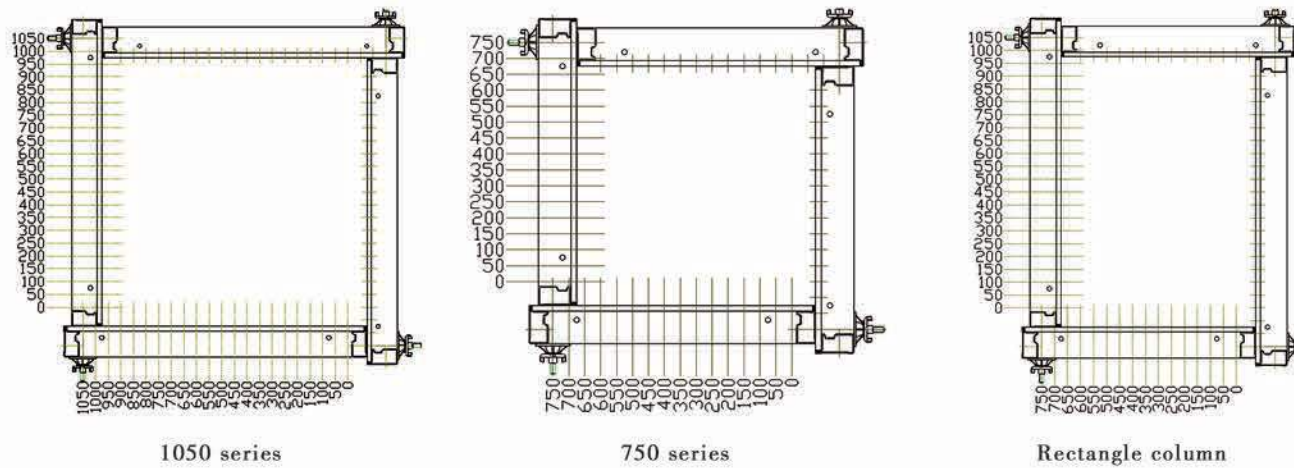

## 03 Column Formwork

### ► Characteristics

Allowable pressure is 80KN/m<sup>2</sup>. Faster and easy operation.  
The dimension for column is adjustable.



## Accessories

Name & Sketch	Weight	Tech. parameter	Remarks
 Panel	422.96kg	3000X2400mm	
	205.37kg	3000X1200mm	
	165.09kg	3000X900mm	
	122.66kg	3000X600mm	
	80.16kg	3000X300mm	
 Panel	53.70kg	1200X600mm	
	33.52kg	1200X300mm	
	43.18kg	900X600mm	
	26.17kg	900X300mm	
	30.94kg	600X600mm	
	18.13kg	600X300mm	
 Corner Formwork	143.34kg	3000X400X400mm	
	61.13kg	1200X400X400mm	
	33.98kg	600X400X400mm	
	16.53kg	300X400X400mm	
 Clamp	4.93kg	Lmax=100mm	
	6.54kg	Lmax=270mm	
 Hook	9.27kg		
 Console Bracket	21.56kg		
 Pull-push Prop	14.42kg	L=950-1550mm	
	21.15kg	L=1850-3250mm	
	27.82kg	L=2550-4750mm	
	33.37kg	L=4650-6000mm	
	102.57kg	L=6000-10000mm	

## Formwork System

### Steel Formwork



#### Characteristics

- No assembling, easy operation with formed formwork.
- High stiffness, make perfect shape for concrete.
- Repeatedly turnover is available.
- Widely applied range, such as building, bridge, tunnel, etc.



# Vertical Structure Support System

## Single-Side Bracket

- ▶ During single-sided concreting, the concrete pressure is transferred into the sub-structure by means of the single-side bracket.

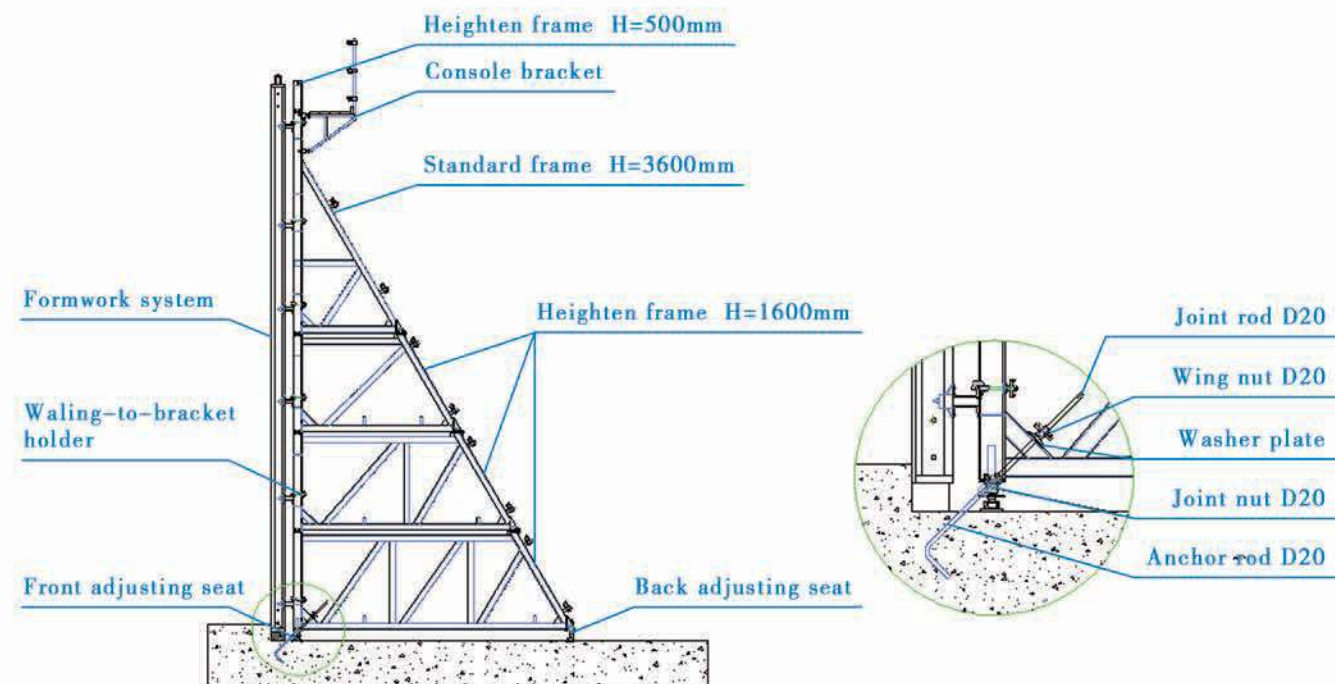

### ▶ Characteristics

For concrete heights up to 8.0m and a fresh concrete pressure up to a maximum of 60KN/m<sup>2</sup>.  
 Good standard performance and versatility.  
 Fast element coupling, all units can be quickly connected.  
 The finished wall is excellent and absolutely waterproof.  
 Optimized sizes for transportation.



### ▶ Design Principle



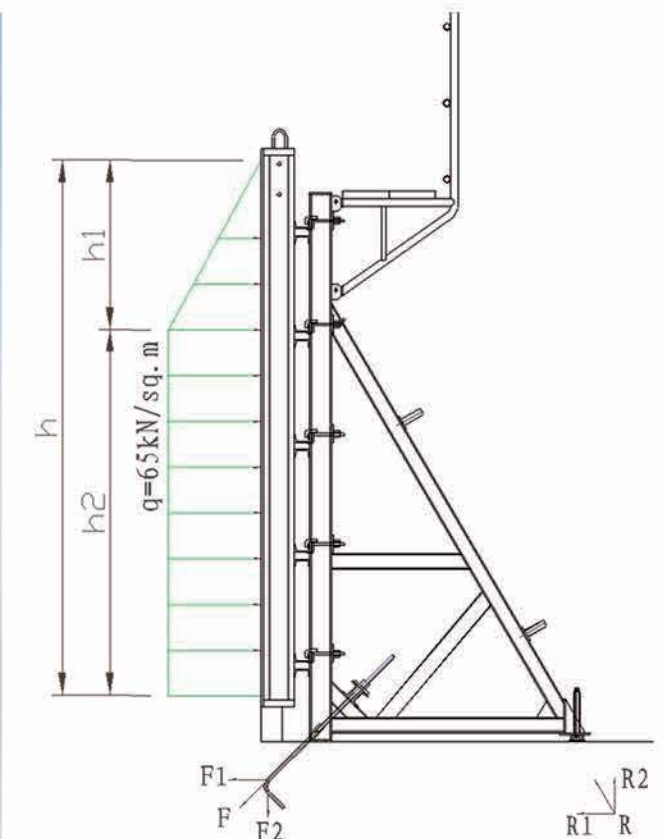







There is no wall-through tie-rod in the single-side bracket system. The whole system is adjusted by the anchor system and the regulator system.  
 The stress situation from the sketch above. F1 can resist the side pressure of the concrete and F2 can resist the rising force. R can not only bear the gravity force of the bracket, but also the side pressure of the concrete. This stress system is simple, reasonable and also with convenience and high safety.







# Vertical Structure Support System

## Accessories

Name & Sketch	Weight	Tech. parameter	Remarks
 Single Side Bracket	236.31kg	H=3600mm	
 Single Side Bracket	201.08kg	H=1600mm	
 Single Side Bracket	277.89kg	H=1600mm	
 Single Side Bracket	355.75kg	H=1600mm	
 Single Side Bracket	16.55kg	H=500mm	
 Front Adjusting Seat	8.53kg		
 Back adjusting seat	5.13 kg		
 Turnover Bolt D20	2.09kg	D20	
 Embedded Bolt D20	2.41kg	D20	
 Scaffold Bracket	14.03kg		

## Accessories

Name & Sketch	Weight	Tech. parameter	Remarks
 Connecting Bolt D20	2.00kg	D20	
 Wing Nut D20	0.67kg	D20	
 Counter Plate	1.26kg	120X120mm	

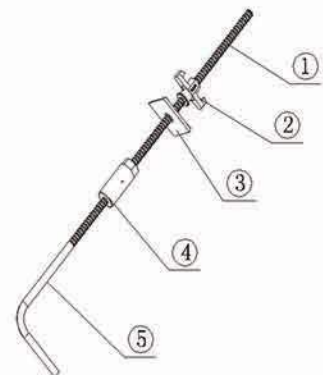
Sketch	Name	Tech. parameter	Remarks
	① Turnover Bolt ② Wing Nut D20 ③ Counter Plate ④ Connecting Bolt ⑤ Embedded Bolt	D20 L=700mm D20 120X120mm D20 D20 L=550mm	All the parts can be reused except embedded bolt.

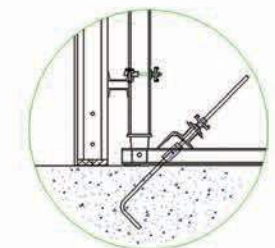
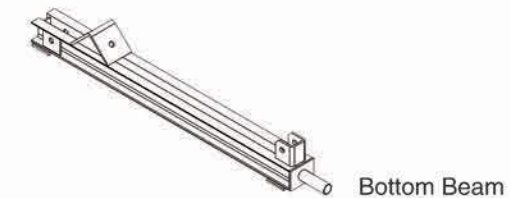

# Vertical Structure Support System

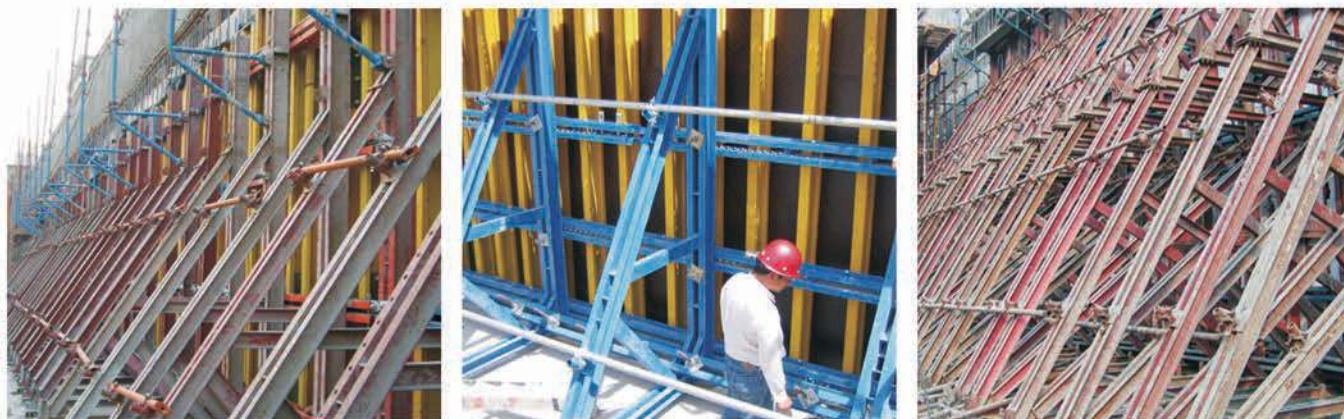

## Single-side Climbing Formwork

Single-side climbing formwork have the similar structure. They are mainly used in the concrete pouring of dam, pier, and guy anchor, concrete protecting wall, tunnel, underground workshop and so on. Because the concrete lateral pressure is entirely supported by anchor system and bracket, the wall-through tie-rod and additional reinforcement are not needed. The construction is easy, rapid and economical; the concrete surface is smooth. They are perfect formwork system for single-side wall and large areas' concreting.

DP-180

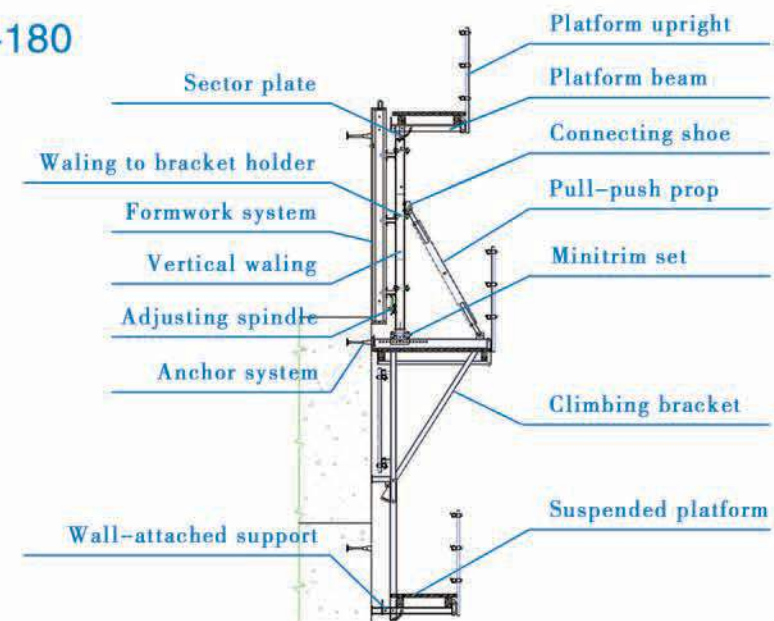

DP-240

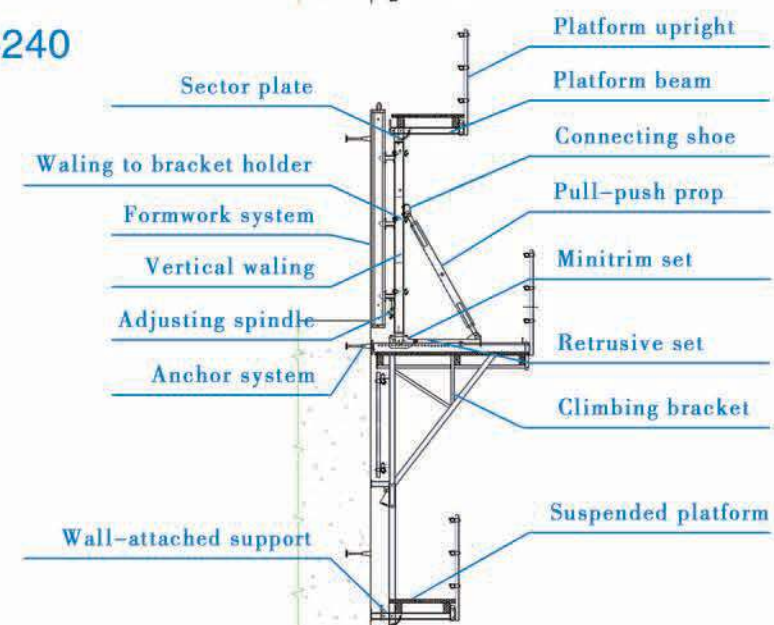

# Vertical Structure Support System

## 01 Bottom beam anchor system

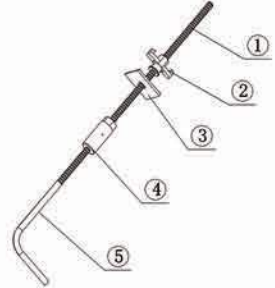
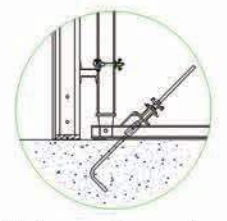
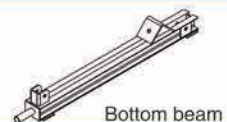
Sketch	Tech. parameter	Weight	Remarks
	① Joint rod D20, L=700 ② Wing nut D20 ③ Cast washer plate 120x120 ④ Joint nut D20 ⑤ Anchor rod D20 L=675	1.90kg 0.67kg 1.26kg 2.00kg 1.95kg	 All the parts can be reused except anchor rod
		42.01kg	

## 02 Wall anchor system

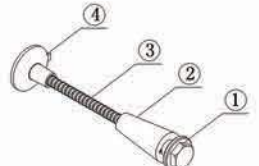
Sketch	Tech. parameter	Weight	Remarks
	① Tensile bolt M36/L=80 ② U-climbing cone M36/D20 ③ High-strength rod D20/L=300 ④ Anchor plate D20	1.22kg 1.77kg 0.81kg 0.65kg	Wall anchor system is the most important supporting part. There into, tensile bolt and V-climbing cone can be taken out for reusing.

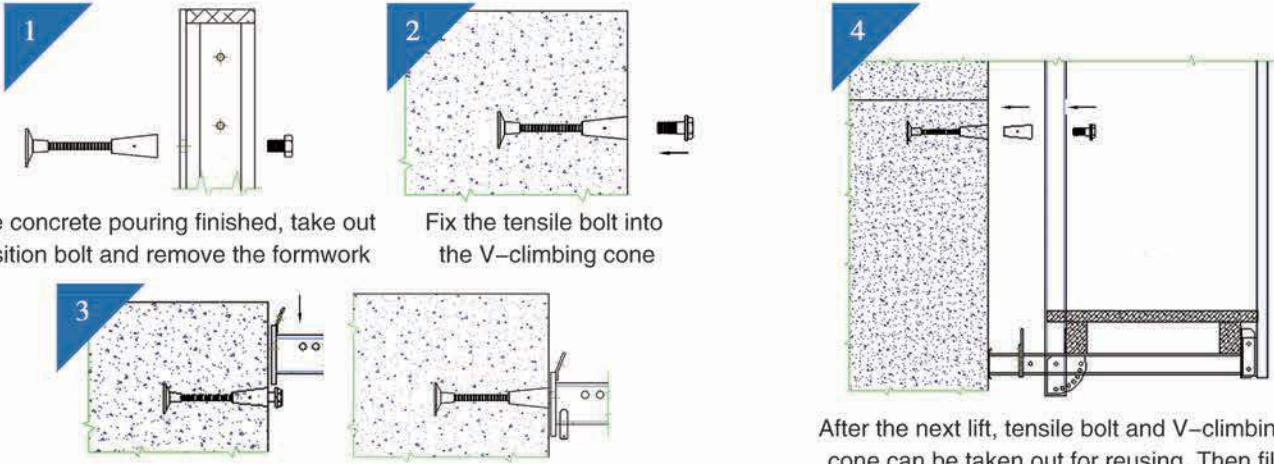



















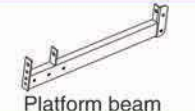

1 After the concrete pouring finished, take out the position bolt and remove the formwork

2 Fix the tensile bolt into the V-climbing cone

3 Lift the climbing bracket and hang it on the tensile bolt, then insert the safe pin. Make sure the bracket and tensile bolt are fixed firmly

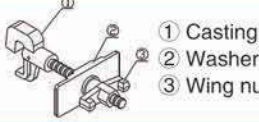
4 After the next lift, tensile bolt and V-climbing cone can be taken out for reusing. Then fill the holes left by V-climbing cone

## 03 Standard components of bracket system

Name & Sketch	Tech. parameter	Name & Sketch	Tech. parameter
	154.29kg		198.72kg
	H=3285mm 97.49kg		20.32kg
	18.86kg		20.60kg
	φ 25/L=250mm 0.92kg		6.17kg
	Adjustable range: 1900~2700mm 35.04kg		φ 25 /L=155mm 0.55kg
	H=2160mm 22.84kg		H=1600mm 6.72kg
	12.62kg		2.17kg
	2.50kg		φ 25 1.10kg
	60x140mm ① Casting hook head 0.92kg ② Washer plate 0.60kg ③ Wing nut D15 0.40kg		M36/ L=50mm 0.80kg
	3.53kg		φ 4 0.023kg

# Vertical Structure Support System

## ► The assemble process (Take DP-180 as an example)

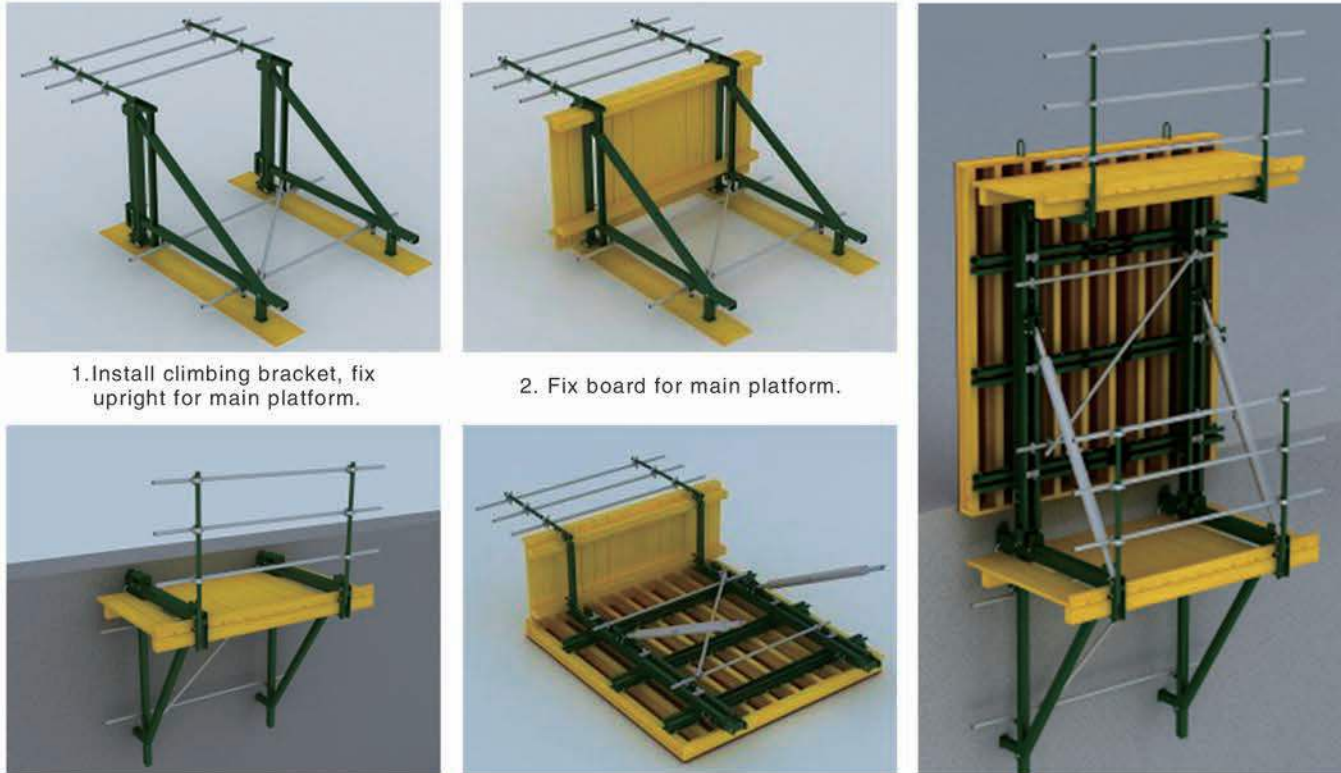

1. Install climbing bracket, fix upright for main platform.

2. Fix board for main platform.

3. Lift the brackets, hang them on the anchor shoes and insert the safe pins.

4. Connect pull-push props and vertical waling with the formwork system and install operation platform.

5. Lift the whole formwork.

## ► The pouring process ( take DP-180 system as an example )

### The first pouring

The lateral pressure is supported by bottom beam anchor system during the first pouring. Embedding the formwork anchor system in the wall which will be the most important supporting parts during the next pouring.

### The second pouring(the first lift)

The climbing brackets are used in the second pouring, which are fixed on the anchor system in the finished wall.

### The third pouring(the second lift)

Fix the suspend platform under the whole system, the workers can remove the tensile bolt and V-climbing cone on the platform and then fill the holes left by the V-climbing cone. The later lifts are standard same as the second lift until the pouring is finished.

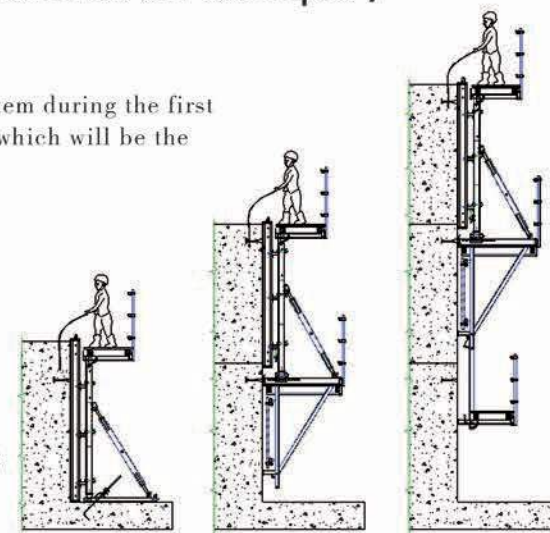

The first pouring    The second pouring    The third pouring

## ► The adjusting of inclination

DP-180 system can be inclined by adjusting pull-push prop. The Max. angle is 30° .  
The sketches are shown below:DP-180

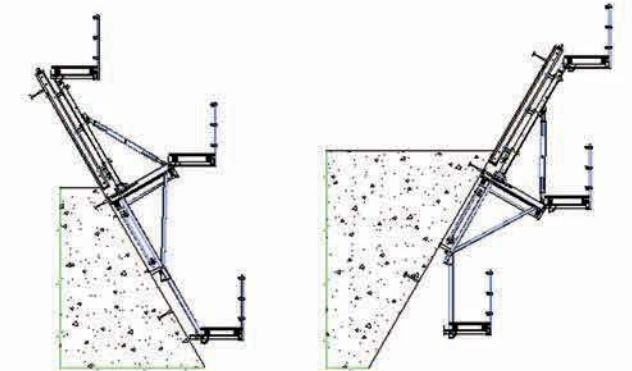

# Vertical Structure Support System

## Climbing Bracket



### ► Characteristics

#### High bearing capacity

The high loading capacity of the brackets allow very large scaffold units. This saves the number anchor points required as well as reducing climbing times.

#### Simple moving procedure by crane

Through the strong connection of formwork together with the climbing scaffold, both can be moved as a single climbing unit by crane. Thus valuable time-savings can be achieved.

#### Fast striking process without a crane

With the retrusive set, large formwork elements can also be retracted quickly and a minimum of effort.

#### Safe with work platform

The platforms have assembled firmly with bracket and will be climbing together, without scaffolding but can work safely in spite of your high location.

### ► Structures

#### CB-240

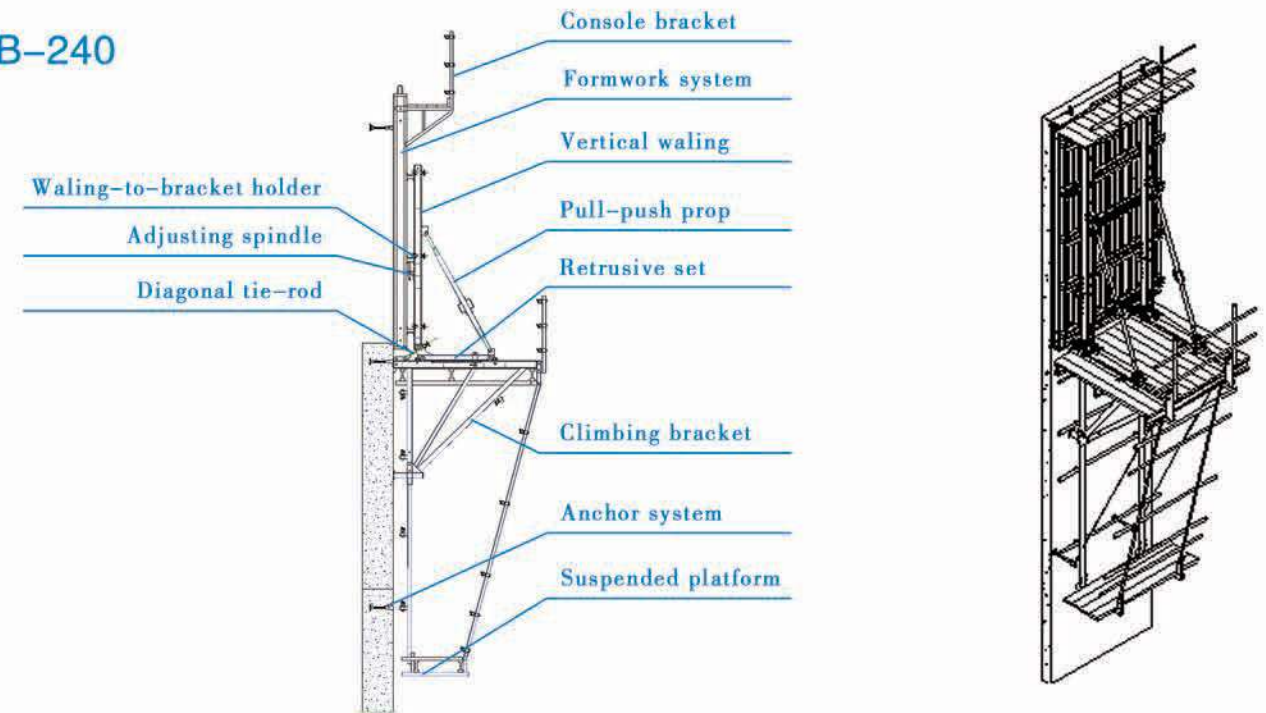



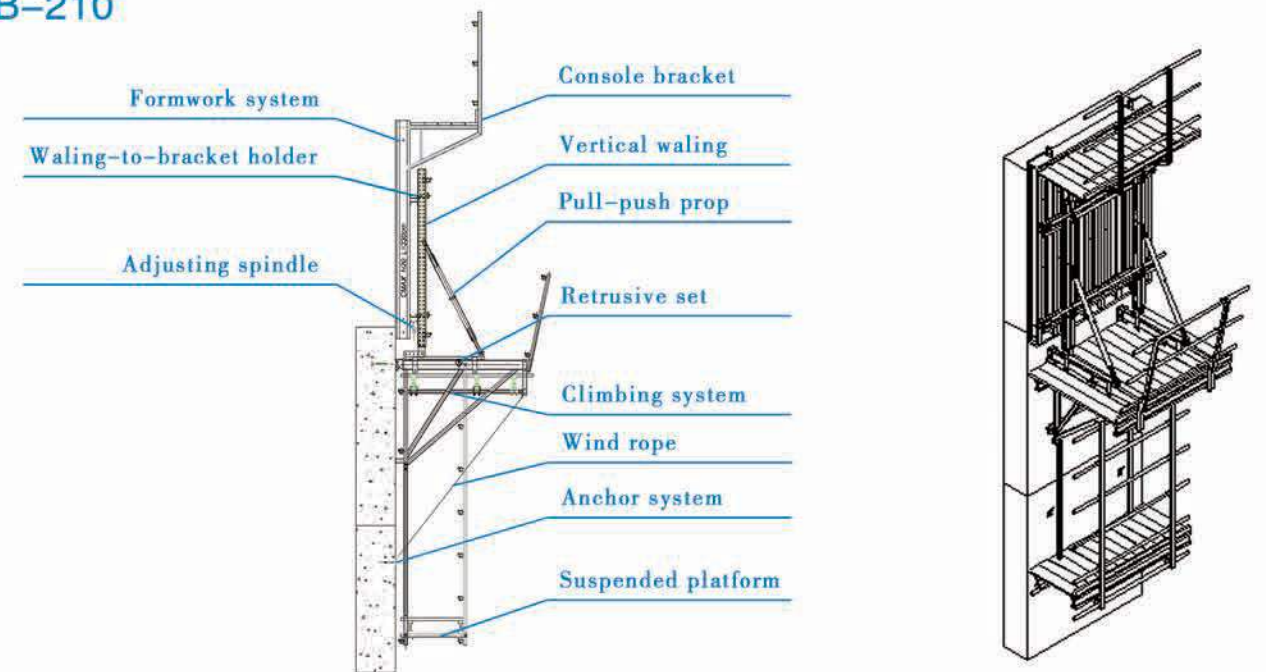





#### CB-210



# Vertical Structure Support System

## Accessories

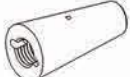
Name & Sketch	Tech. parameter	Name & Sketch	Tech. parameter
 Climbing Bracket	88.26kg	 Retrusive Set	25.68kg
 Vertical Waling	67.66kg	 Pull-Push Prop	14.45kg
 Upright for main Platform		 Upright A	12.37kg
 Upright B	20.70kg	 Platform Beam	6.17kg
 Safe Pin	0.6kg φ 20X254mm	 Pin for Vertical Waling	0.32kg φ 20X120mm
 Adjusting Spindle	3.34kg	 Fastening	0.82kg
 Connector	0.59kg	 Rope Connecting Plate	0.65kg
 Anchor Shoe	1.35kg	 Construction Bolt	0.5kg M30X50mm
 Ack Bolt	0.27kg M30	 Tensile Bolt	0.79kg M30X110mm
 Climbing Cone	1.64kg M30/D15	 Anchor Plate	0.65kg D15X115mm

## Accessories

Name & Sketch	Name & Sketch	Name & Sketch	Name & Sketch
 Anchor Plate	0.50kg D15	 Tie Rod	0.45kg D15X300mm

## Assembly Process

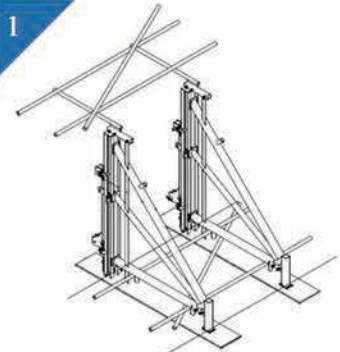
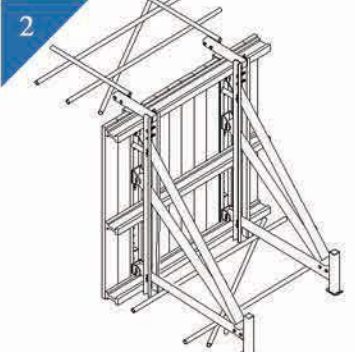
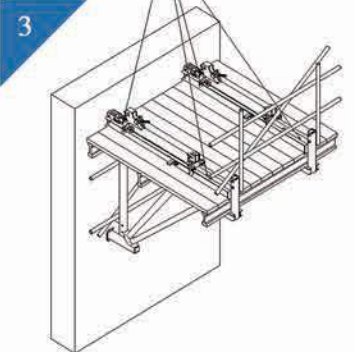
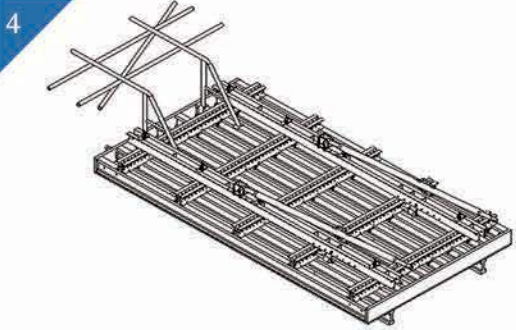
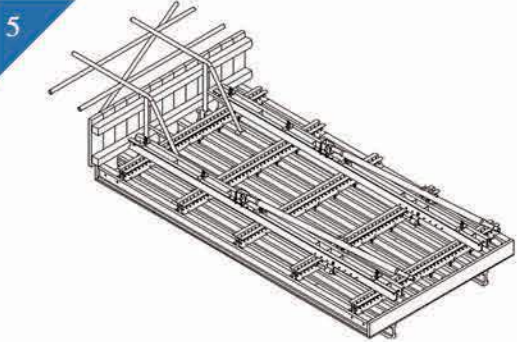
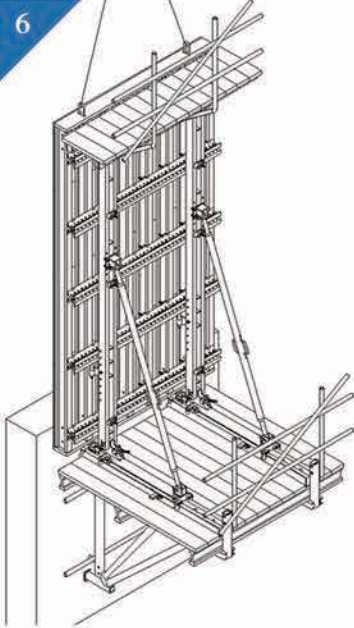
-   
Install climbing bracket, fix upright for main platform.
-   
Fix board for main platform.
-   
Hang the brackets on anchor shoes and insert the safe pins.
-   
Connect pull-push props & vertical walers to the formwork system.
-   
Connect the up platform to the formwork system.
-   
Lift the whole formwork to the main platform and fix them to retrusive set.

## Vertical Structure Support System



## Auto — Climbing Bracke

- ▶ The power of the auto-climbing formwork is the hydraulic system, which includes the oil cylinder and two commutators. The commutators can control the climbing of climbing rail and the bracket. The steel rail and the bracket can inter-climbing, so the whole system will climb up steadily. Cranes are not needed during the construction. It's easy to operate, highly efficient and safe. It's the best choice for the construction of high buildings and bridges.
- ▶ There are mainly two types of standard auto-climbing brackets, ACB-100 and ACB-50, the figure means the push power of cylinder with unit of KN.



### Structures

#### ACB-100

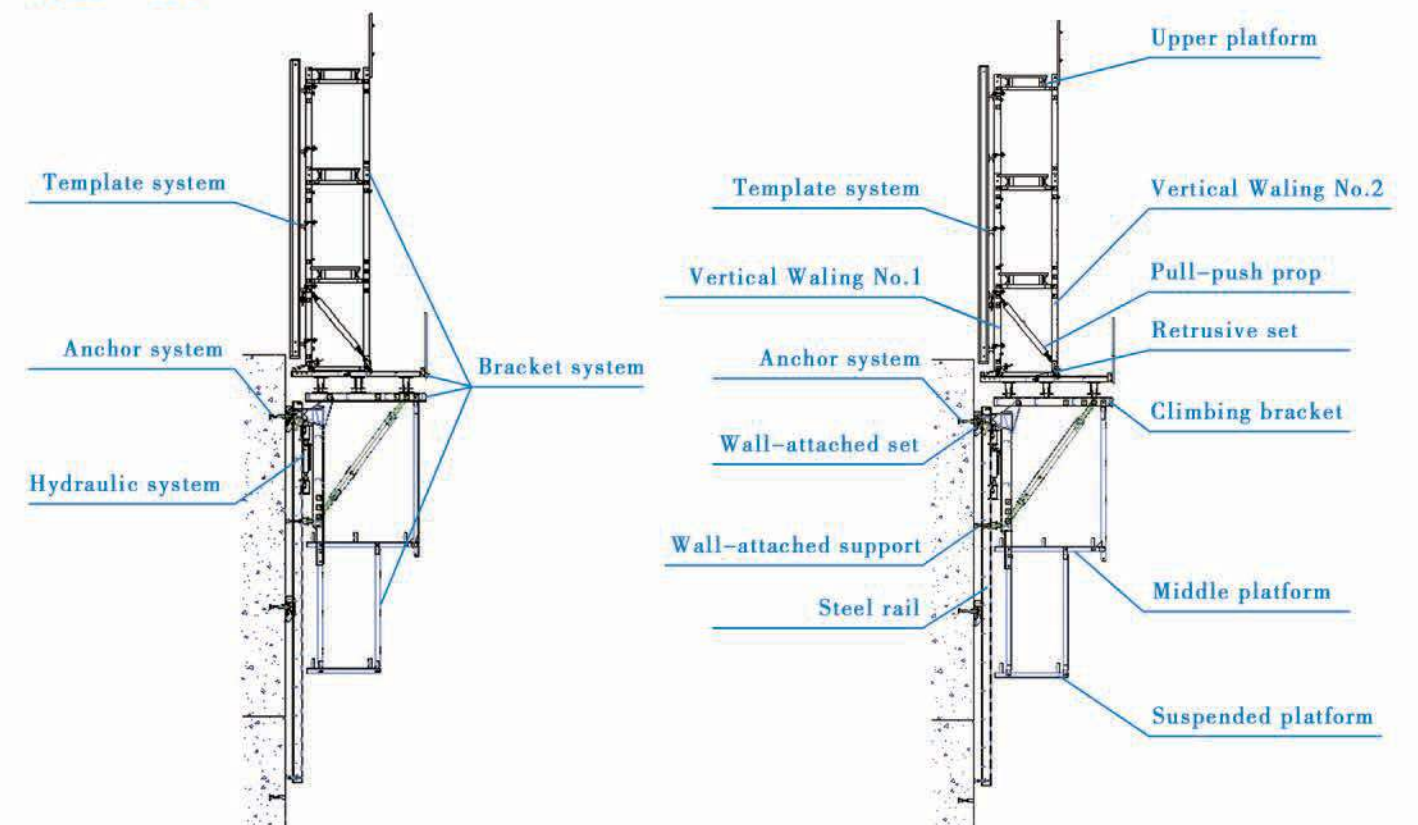

# Auto — Climbing Bracke

## ACB-50

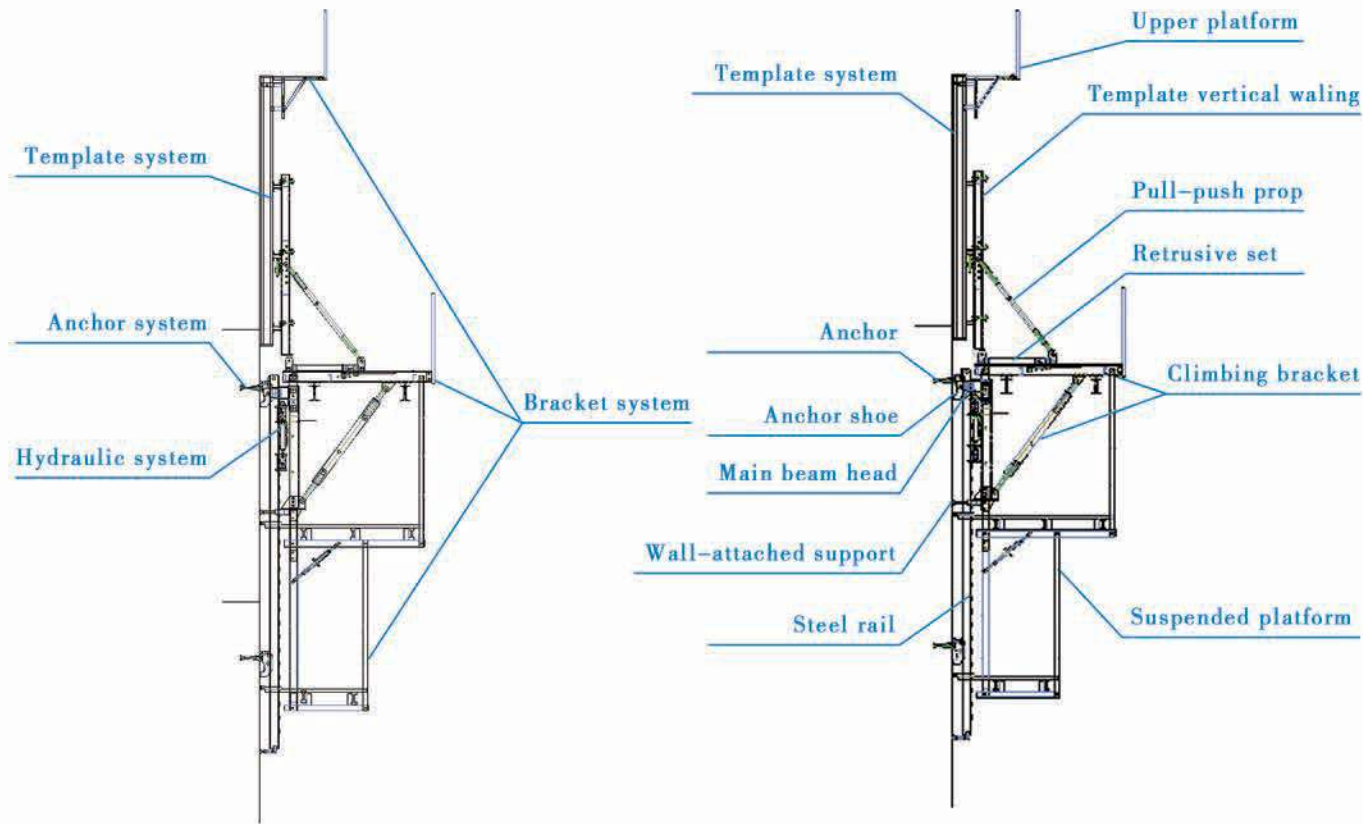

### ► Characteristics

#### Crane-independent

Crane-independent forming, striking and climbing speeds up the work procedures on the construction site and also makes them independent of each other. This means the planned sequences can be maintained along with guaranteeing high productivity levels. The crane can therefore be used for other tasks.

Hydraulic system is mainly made of two commutators, oil cylinder and power distribution system. The commutators can control the climbing of climbing rail and bracket.



### Perfect load bearing anchor system

Anchor system is the most important supporting part. The system is made of five parts shown below. Thereinto, tensile bolt, V-climbing cone and washer can be taken out for reusing after the concrete pouring finished. There are two kinds of anchor systems, A & B. A is matched with single anchor shoe and B is matched with double anchor shoe.

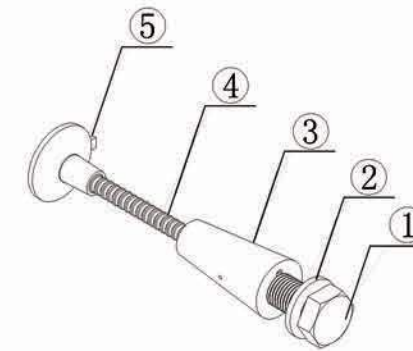

#### Anchor Assembly A ( Matched with single anchor shoe )

① Tensile Bolt M42	1.60kg
② Washer 78/52	0.21kg
③ V-climbing Cone M42/D20	2.78kg
④ High-strength Rod D20/L=300	0.81kg
⑤ Anchor Plate D20	0.65kg

#### Anchor Assembly B (Matched with double anchor shoe)

① Tensile Bolt M36	1.05kg
② Washer 65/46	0.14kg
③ V-climbing Cone M36/D20	1.77kg
④ High-strength Rod D20/L=300	0.81kg
⑤ Anchor Plate D20	0.65kg

### High bearing capacity and safe

The stable working platforms are able to carry large loads, e.g. the storage of reinforcing steel for the next climbing section. Generously-sized working platforms, the well thought-out design for handling very high wind loads and the patented control function of the climbing mechanism are some of the special details contained within the comprehensive safety concept.

The system will furnish omnidirectional platform, the construction organizations don't need to set up additional operation platform. Platforms adjusted to suit the angle of inclination. The horizontal working areas thus created provide safe and comfortable conditions for reinforcement work, shuttering and striking, concreting and finishing.

The bracket will not fall to the ground until the construction is finished, the field will be saved and the impacting breakage will be reduced ( especially the panel ).



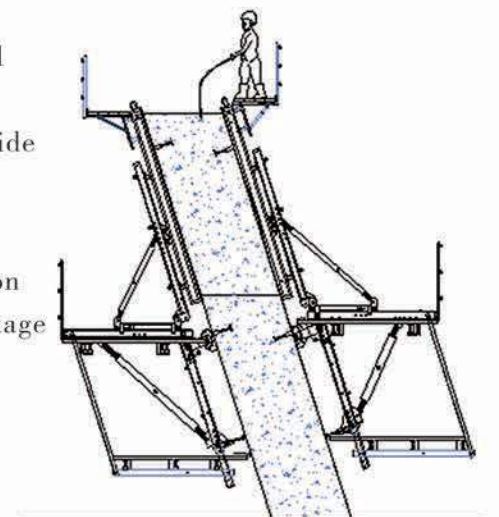













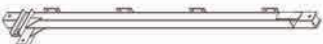

The formwork can climb itself and cleaning work can be done in the same situs, the used times of tower crane will be greatly reduced.

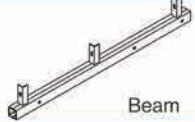



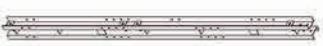



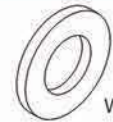

# Auto — Climbing Bracke

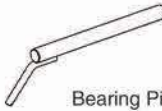
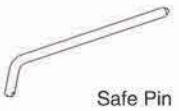
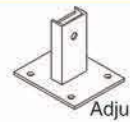
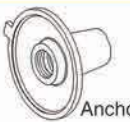
## Accessories

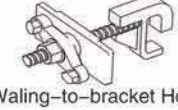
Name & Sketch	Tech. parameter	Name & Sketch	Tech. parameter
 Retrusive Set	64.63kg	 Single Retrusive Set	36.80kg
 Climbing Rail	L=8000mm 445.69kg L=6000mm 204.89kg	 Upright for Climbing Bracket	274.22kg
 Main Beam	127.05kg	 Pull-push Prop for Vertical Waling	88.40kg
 Wall-attached Support	54.58kg	 Retrusive Set Assembly	116.53kg
 Connecting Rod	58.04kg	 Upright	29.63kg
 Beam	46.08kg	 Connecting Rod A	37.31kg
 Connecting Rod B	40.44kg	 Platform Beam	32.92kg
 Vertical Waling A	127.67kg	 Vertical Waling B	108.16kg
 Beam for Upper Platform	17.76kg	 Upright for Platform H=1350mm	6.16kg
 Pull-push Prop	32.85kg	 Washer	φ 78/ φ 42.5 0.21kg

## Accessories

Name & Sketch	Tech. parameter	Name & Sketch	Tech. parameter
 Bearing Pin	5.13kg	 Safe Pin	1.22kg
 Adjusting Seat	10.56kg	 Anchor Plate	D26.5 1.09kg D20 0.65kg
 Tensile Bolt	M36X90mm 1.05kg M42X90mm 1.6kg	 Waling-to-bracket Holder	1.92kg
 Welded Adjusting Spindle	4.49kg	 Tie Rod	D20/L=300mm Max. load:270kN D26.5/L=350mm Max. load:400kN
 U-climbing cone Tool	M42 0.67kg M36 0.47kg	 V-climbing Cone	M42/D26.5 2.55kg M36/D20 1.77kg

## 组装步骤

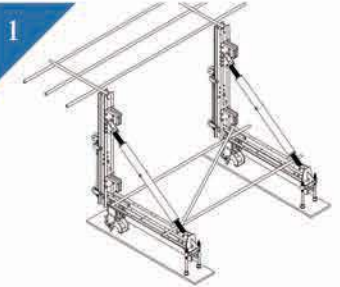
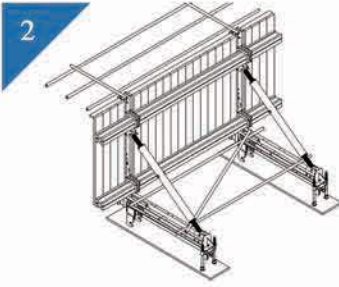
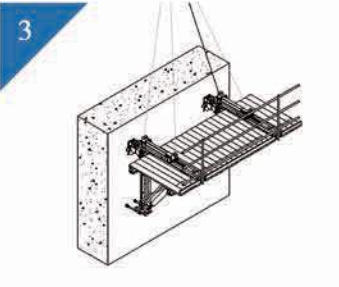
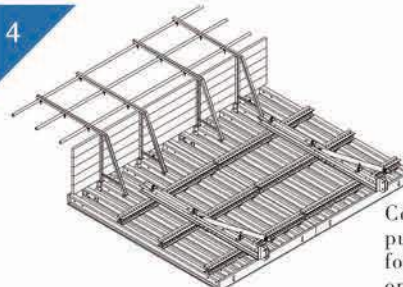
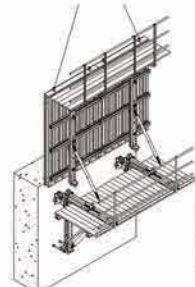
-  Assemble climbing bracket, fix upright for main platform
-  Fix board for main platform
-  Lift the brackets, hang them on the anchor shoes and insert the safe pins
-  Connect vertical waling and pull-push prop with the formwork system, install operating platform
-  Lift the formwork system and put them on the retrusive set, adjust the formwork

# Auto — Climbing Bracke

## ► Sketch of Climbing Vertically

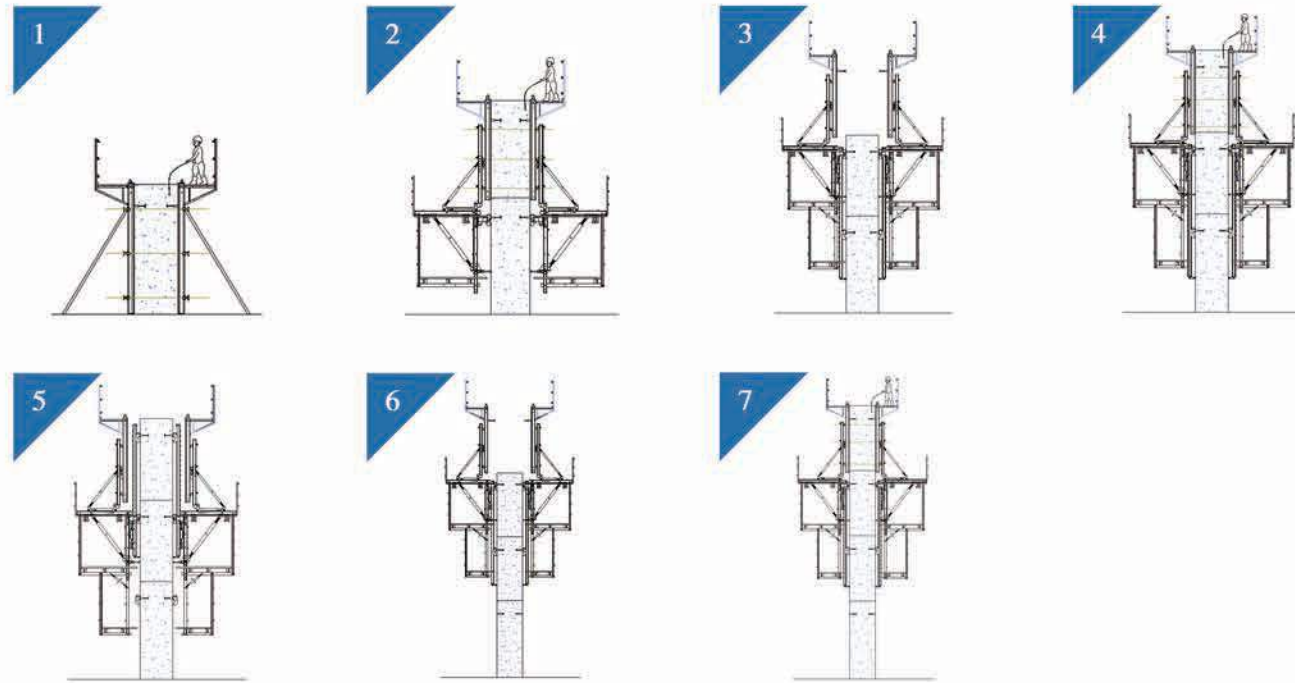

## ► Sketches of Inclined Climbing

